

Green Power

Unveiling the Future of Energy with Seaweed-Based Paper Batteries

In our quest for sustainability, energy storage stands as a crucial frontier. The increasing demand for eco-friendly solutions has led to groundbreaking innovations that marry traditional wisdom with cutting-edge technology. Among these, the seaweed-based paper battery emerges as a pioneering concept, harnessing the untapped potential of seaweed, a renewable resource, to create a sustainable alternative to conventional batteries. This ingenious blend of natural materials and modern engineering offers a promising path towards greener energy storage options. By exploring the potential of such sustainable technologies, we are not just addressing the immediate need for cleaner energy solutions but also paving the way for a future where technology and nature exist in harmony, promising a brighter, more sustainable world.

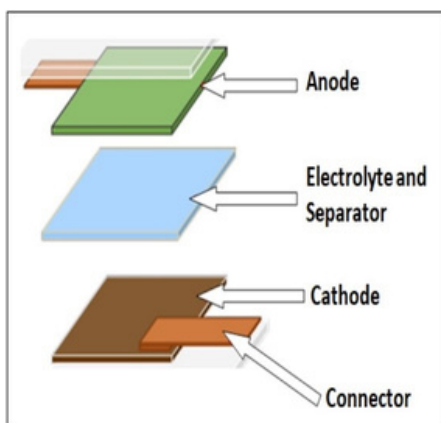
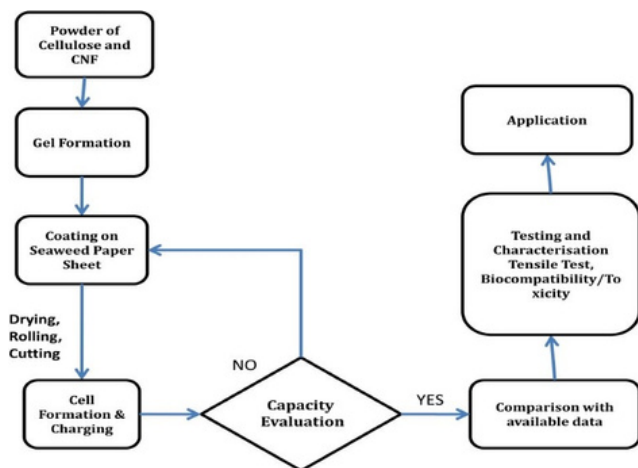

The Need for Sustainable Batteries

The reliance on conventional batteries, though a cornerstone of modern convenience, casts a long shadow on our environmental landscape. These batteries, often laden with heavy metals like lead, mercury, and cadmium, pose significant pollution challenges once they reach the end of their lifespan. The disposal process can lead to these harmful substances leaching into soil and waterways, endangering ecosystems and human health alike. Additionally, the limited biodegradability of traditional batteries exacerbates the accumulation of electronic waste, a growing concern in our increasingly digital world.

This scenario underscores the urgent need for sustainable battery technologies. Eco-friendly alternatives promise not just to mitigate these environmental hazards but also to offer practical advantages, including enhanced biodegradability and the use of renewable resources. The shift towards sustainable batteries isn't just an environmental imperative but a practical necessity, paving the way for cleaner, greener energy storage solutions that align with the principles of circular economy and sustainable development.

Seaweed-Based Paper Battery

The seaweed-based paper battery represents a revolutionary stride in the field of sustainable energy storage, born from the intersection of ecological mindfulness and technological innovation. This battery leverages the natural abundance and biodegradability of seaweed, a fast-growing marine resource, as its primary material. Its composition is further enhanced with other sustainable substances, including carbon

nanotubes and polymer binders, to create a lightweight, efficient, and environmentally friendly power source.

The rationale behind using seaweed and similar sustainable materials lies in their minimal environmental impact. Seaweed grows abundantly in marine environments without the need for freshwater or fertilizers, making it a low-impact resource. When transformed into a paper battery, it not only provides a biodegradable alternative to conventional batteries but also taps into the inherent properties of seaweed to store energy efficiently. This innovative approach not only addresses the pressing need for sustainable energy solutions but also showcases the potential of natural resources in advancing green technology.

Manufacturing Process

The manufacturing process of the seaweed-based paper battery is a testament to sustainable engineering, seamlessly blending eco-conscious materials with innovative production techniques. The journey begins with the careful extraction of cellulose from seaweed, chosen for its renewable nature and biodegradability. This cellulose serves as the foundational material, to which carbon nanotubes (CNTs), polymer binders, and anode and cathode materials are added, each selected for their environmental compatibility and performance in energy storage.

In the next stage, these components are mixed to create a composite solution. This mixture is then cast onto sheets made from seaweed, forming the cellulose composite paper, a crucial component of the battery. Once dried, this paper undergoes a precise layer-by-layer coating process, where anode and cathode materials are alternately applied.

This meticulous approach ensures uniformity and optimizes the battery's ability to store and discharge energy efficiently. Throughout this process, sustainability is paramount. From the biodegradable base of seaweed cellulose to the use of eco-friendly additives and energy-efficient manufacturing steps, every aspect of the seaweed-based paper battery's creation reflects a commitment to minimizing environmental impact, heralding a new era of green technology in energy storage solutions.

Performance and Benefits

The seaweed-based paper battery distinguishes itself through remarkable performance metrics and environmental benefits, setting a new standard in the realm of sustainable energy storage. Notably, this innovative battery showcases a 58% reduction in weight and a 16.7% increase in voltage capacity compared to conventional AA 1.5–3.5 V Li-ion batteries. It boasts an impressive output of 4.5 V and 120 mAh, significantly surpassing the 30 mAh capacity of standard paper batteries. Such enhancements in efficiency illuminate the battery's ability to store and deliver energy more effectively, catering to the demands of modern electronic devices with a lighter, more potent power source.

Beyond its performance, the seaweed-based paper battery's biodegradability marks a substantial environmental advantage. Unlike traditional batteries, which linger in landfills and pose contamination risks, this biodegradable alternative decomposes naturally, reducing waste and minimizing ecological impact. By harmonizing high energy storage capacity with eco-friendly attributes, the seaweed-based paper battery emerges as a superior solution, bridging the gap between technological advancement and environmental stewardship.

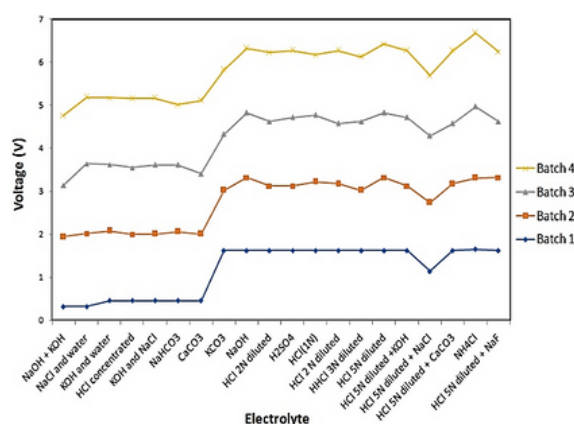
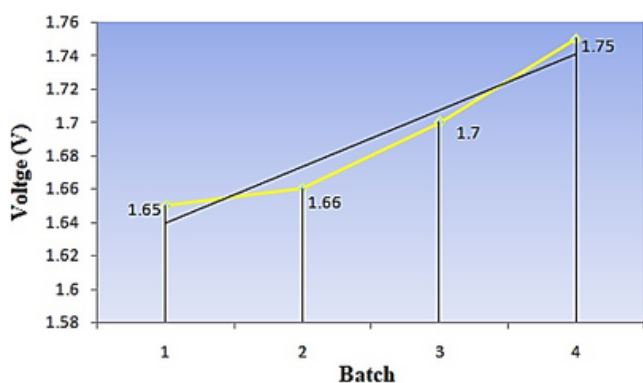

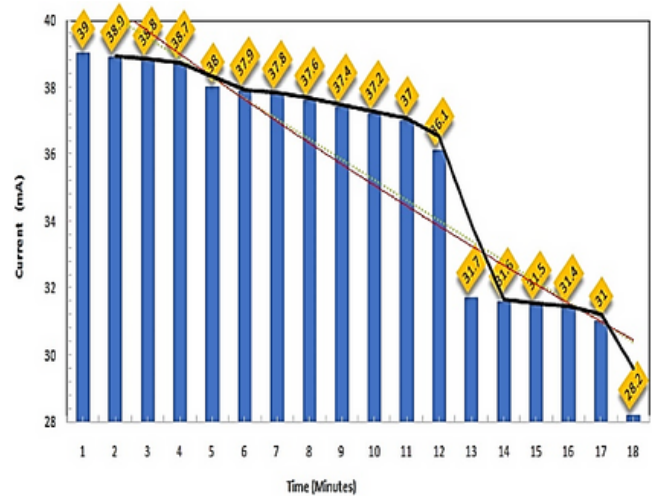
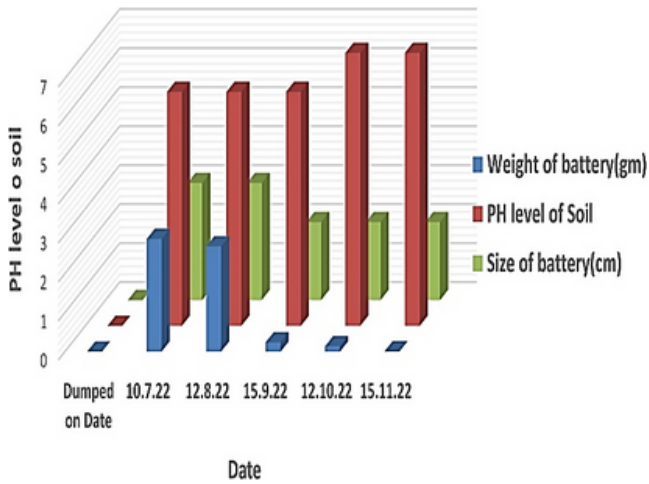

Application Scenarios

The seaweed-based paper battery's lightweight, biodegradable nature, and enhanced energy capacity unlock a plethora of applications across various sectors, demonstrating its versatility and potential for transformative impact. In the realm of medical devices, its non-toxicity and compact form factor make it ideal for powering wearable health monitors and implantable devices, ensuring patient safety and comfort. Electronics, from smartphones to laptops, can benefit from its eco-friendly footprint and high performance, contributing to the sustainability of consumer products.

Additionally, in sustainable agriculture, this innovative battery can energize soil sensors and irrigation systems, promoting efficient resource use and supporting eco-conscious farming practices. These diverse applications not only highlight the battery's adaptability but also its role in advancing sustainable solutions across industries, paving the way for a greener, more innovative future.

Challenges and Future Direction

While the seaweed-based paper battery heralds a sustainable future in energy storage, its path to widespread adoption is not without challenges. Scalability remains a significant hurdle, with current production processes perhaps not yet optimized for mass manufacture. The sourcing of high-quality, sustainable seaweed at scale also presents logistical challenges. Future research is poised to tackle these obstacles, focusing on refining manufacturing techniques to enhance scalability and efficiency. Additionally, exploring more diverse and abundant seaweed species could alleviate sourcing concerns.

Conclusion

The development of the seaweed-based paper battery marks a significant stride toward sustainable energy storage, merging innovation with eco-consciousness. To fully harness its potential, ongoing research and collaborative efforts are essential. Together, we can refine and bring these groundbreaking solutions to market, paving the way for a more sustainable and energy-efficient future.



Dr. Unnati Joshi

Director Research
Professor, Mechanical Engineering Department
Faculty of Engineering and Technology